

## L1672

### 5. Features of L1672 Series

#### ■ Basic Specifications

- 16 Characters × 2 lines
- STN gray type LCD is used
- 5 × 7 dot matrix + cursor
- 1/16 duty
- 5V single power supply

#### ■ Line up

Type	LCD panel		LED backlight			Operating Temp
	Reflective	Transflective	yellow green	White	None	
L167200J000	●				●	Normal
L1672B1J000		●	●			
L167200P000	●				●	Wide temperature
L1672B1P000		●	●			
L1672D1J000		●		●		Normal

#### Pin Function

No.	Name	Function
1	DB7	Data bus line
2	DB6	Data bus line
3	DB5	Data bus line
4	DB4	Data bus line
5	DB3	Data bus line
6	DB2	Data bus line
7	DB1	Data bus line
8	DB0	Data bus line
9	E	Enable
10	R/W	L: Data write (LCM→MPU) H: Data read (LCM→MPU)
11	RS	L: Instruction code input H: Data input
12	VLC	Liquid crystal driving voltage
13	VSS	GND
14	VDD	Power supply voltage +5V
-	VLED	Anode (1)
-	VLEDG	Cathode (1)

Remark1) LCD panel : NC as LCD Reflective type



# L1672

## ■ Dimensions(D)

Type
L1672B1J000
L1672B1P000
L1672D1J000

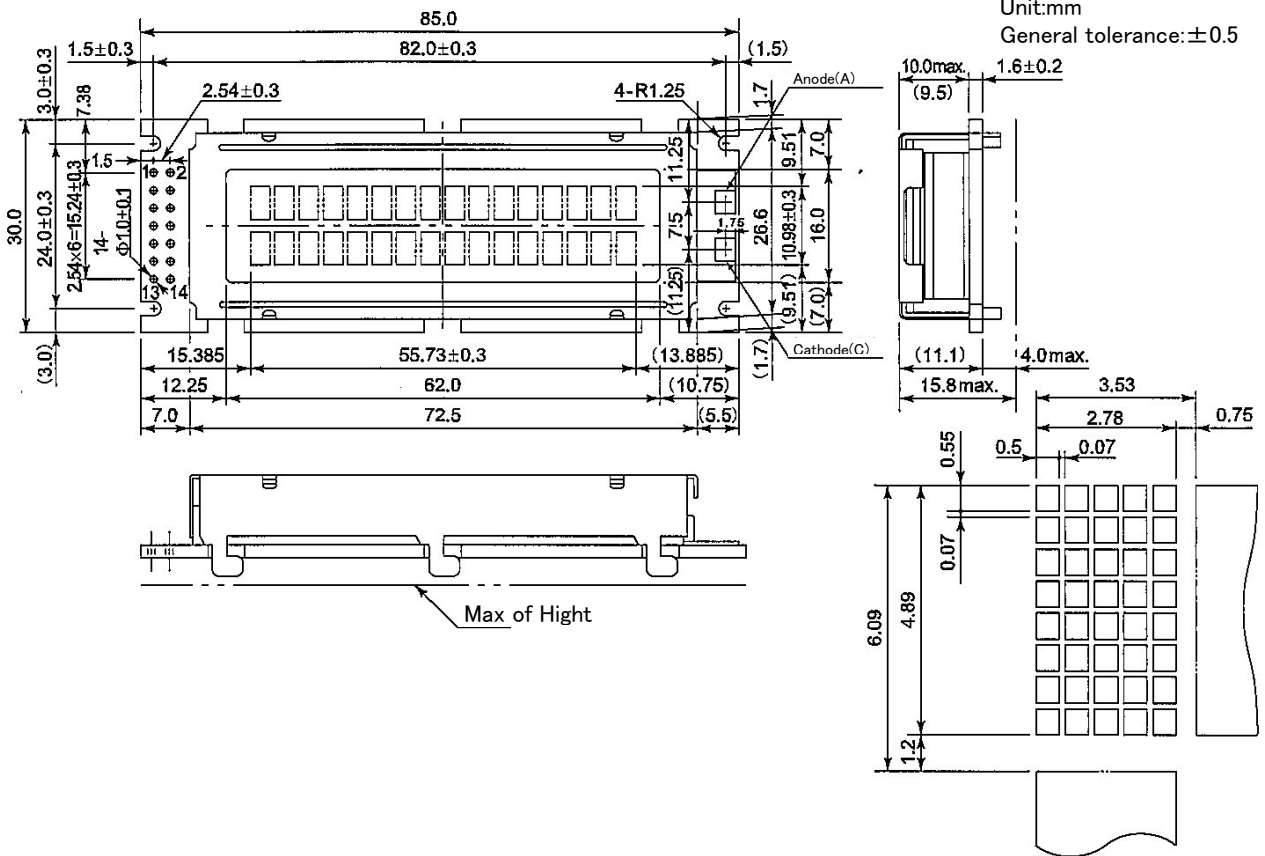

## ■ Block Diagram (E)

Type
L1672B1J000
L1672B1P000
L1672D1J000

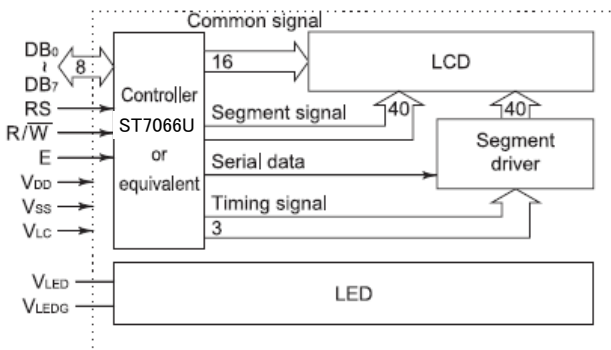

## ■ Power supply (F)

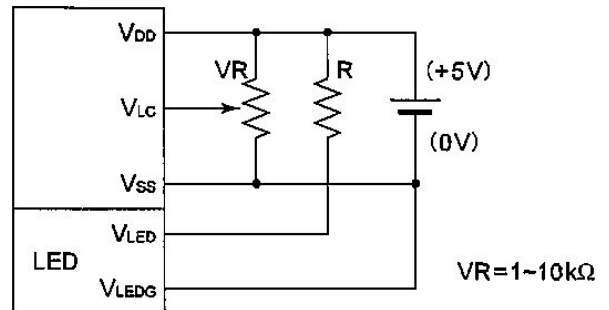

## L1672

---

### ■ LED Backlight Circuit (G)

Type
L1672B1J000
L1672B1P000

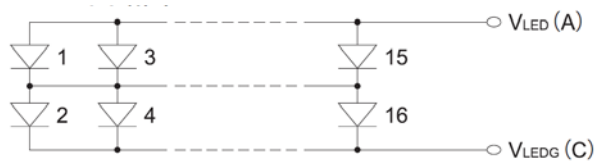

### ■ LED Backlight Circuit (H)

Type
L1672D1J000

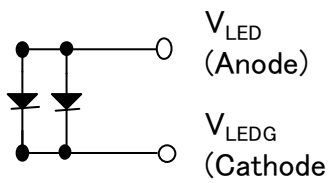

Normal Temp. STN LCD Module

Type
L167200J000
L1672B1J000

■ Electrical Characteristics

I. Absolute Maximum Ratings

VSS = 0V

Item	Symbol	Conditions	Min.	Max.	Unit
Power supply voltage	VDD		-0.3	6.0	V
	VLC		VDD-10	VDD+0.3	V
Input voltage	VIN		-0.3	VDD+0.3	V
Operating temperature	Topr		0	+50	°C
Storage temperature	Tstg		-20	+60	°C
Storage humidity	Hstg	≤48hrs	+20	+85	%RH
	Hstg	≤500hrs	+20	+65	%RH

J. Electrical Characteristics

VDD = 5V ± 5%, VSS = 0V, Ta = 0°C ~ 50°C

Item	Symbol	Conditions	Min.	Typ.	Max.	Unit
Power supply voltage	VDD		4.75	5.0	5.25	V
	VDD-VLC			4.75		V
Input voltage*	High	VIH1	0.7Vdd	-	VDD	V
	Low	VIL1	-0.3	-	0.6	V
Output voltage**	High	VOH1	-IOH=0.1mA	3.9	VDD	V
	Low	VOL1	IOL=0.1mA	-	0.4	V
Current consumption	IDD	Ta=25°C VDD=5V	-	2.0	3.0	mA
	ILC	Vopr=4.75V	-	0.2	1.0	mA

\* Applied to DB0 ~ DB7, E, R/W, RS

Vopr = VDD - VLC

\*\* Applied to DB0 ~ DB7

K. Optical Characteristics

L167200J000
-------------

Viewing angle : 6 o'clock (φ = 0°), Ta = 25°C, Vopr = 4.75V

Item	Symbol	Condition	Min.	Typ.	Max.	Unit
Viewing angle	θ <sub>1</sub>	C ≥ 2.0 φ = 0°	-	-	-15	Deg
	θ <sub>2</sub>		55	-	-	
	θ <sub>2</sub> - θ <sub>1</sub>		70	-	-	

L1672B1J000
-------------

Viewing angle : 6 o'clock (φ = 0°), Ta = 25°C, Vopr = 4.75V, Backlight OFF

Item	Symbol	Condition	Min.	Typ.	Max.	Unit
Viewing angle	θ <sub>1</sub>	C ≥ 2.0 φ = 0°	-	-	-10	Deg
	θ <sub>2</sub>		50	-	-	
	θ <sub>2</sub> - θ <sub>1</sub>		60	-	-	

Common Optical Characteristics

Viewing angle : 6 o'clock (φ = 0°), Ta = 25°C, Vopr = 4.75V, (Backlight OFF)

Item	Symbol	Condition	Min.	Typ.	Max.	Unit
Contrast	C	θ = 20°, φ = 0	2	4	-	-
Response time (rise)	ton	θ = 0° φ = 0°	-	270	400	ms
Response time (fall)	toff		-	60	100	
Response time (rise)	ton	θ = 0°, φ = 0° Ta=0°C Vopr=5.0V	-	720	1100	ms
Response time (fall)	toff		-	170	350	

■ Reference Drawing

Item	L167200J000	L1672B1J000
Dimensions	A	D
Block Diagram	B	E
Power supply	C	F
LED Backlight Circuit	--	G

L. Recommended Operating Voltage

The Recommended Value of (Vopr) for an ambient temperature is as follows.

Vopr = VDD - VLC

Temperature (°C)	-	0	25	50
Vopr (V)	-	5	4.75	4.5

■ LED Backlight

L1672B1J000
-------------

M-1 Absolute Maximum Ratings

Ta = 25°C

Item	Symbol	Standard	Unit
LED Forward current consumption*	IF	200	mA
LED Reverse DC voltage	VR	8	V
LED Allowable dissipation	PD	0.92	W

\* Ambient temperature VS allowable forward current

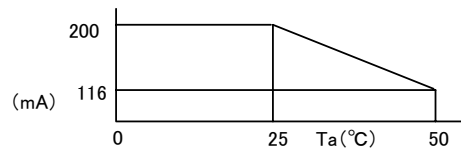

M-2 Optical Characteristics

Ta = 25°C

Item	Symbol	Conditions	Standard	Unit
Surface brightness (panel upper)	Bp	IF=112mA Vopr=0V	8 min. 10 typ.	cd/m <sup>2</sup>
LED reverse life			50,000 typ.	h
LED color			Yellow green	

M-3 Electrical Characteristics

Ta = 25°C

Item/Condition	Symbol	Min.	Typ.	Max.	Unit
LED forward input Voltage If=112mA	VF	3.8	4.1	4.4	V
LED reverse current VR=8V	IR	-	-	0.16	mA

Wide Temp. STN LCD Module

Type
L167200P000
L1672B1P000

■ Electrical Characteristics

I. Absolute Maximum Ratings

VSS = 0V

Item	Symbol	Conditions	Min.	Max.	Unit
Power supply voltage	VDD		-0.3	6.0	V
	VLC		VDD-10	VDD+0.3	V
Input voltage	VIN		-0.3	VDD+0.3	V
Operating temperature	Topr		-20	+70	°C
Storage temperature	Tstg		-30	+80	°C
Storage humidity		≤48hrs	+20	+85	%RH
		≤500hrs	+20	+65	%RH

J. Electrical Characteristics

VDD = 5V ± 5%, VSS = 0V, Ta = -20°C ~ 70°C

Item	Symbol	Conditions	Min.	Typ.	Max.	Unit	
Power supply voltage	VDD		4.75	5.0	5.25	V	
	VDD-VLC			4.8		V	
Input voltage*	High	VIH1	0.7Vdd	-	VDD	V	
	Low	VIL1	-0.3	-	0.6	V	
Output voltage**	High	VOH1	-IOH=0.1mA	3.9	-	VDD	V
	Low	VOL1	IoL=0.1mA	-	-	0.4	V
Current consumption	IDD	Ta=25°C VDD=5V	-	2.0	3.0	mA	
	ILC	Vopr=4.8V	-	0.2	1.0	mA	

\* Applied to DB0 ~ DB7, E, R/W, RS

\*\* Applied to DB0 ~ DB7

K. Optical Characteristics

L167200P000
-------------

Viewing angle : 6 o'clock (φ = 0°), Ta = 25°C, Vopr = 4.8V

Item	Symbol	Conditions	Min.	Typ.	Max.	Unit
Viewing angle	θ <sub>1</sub>	C ≥ 2.0 φ = 0°	-	-	0	Deg
	θ <sub>2</sub>		50	-	-	
	θ <sub>2</sub> - θ <sub>1</sub>		50	-	-	

L1672B1P000
-------------

Viewing angle : 6 o'clock (φ = 0°), Ta = 25°C, Vopr = 4.8V, Backlight OFF

Item	Symbol	Conditions	Min.	Typ.	Max.	Unit
Viewing angle	θ <sub>1</sub>	C ≥ 2.0 φ = 0°	-	-	0	Deg
	θ <sub>2</sub>		50	-	-	
	θ <sub>2</sub> - θ <sub>1</sub>		50	-	-	

Common Optical Characteristics

Viewing angle : 6 o'clock (φ = 0°), Ta = 25°C, Vopr = 4.8V, (Backlight OFF)

Item	Symbol	Condition	Min.	Typ.	Max.	Unit
Contrast	C	θ = 20°, φ = 0°	2	3	-	-
Response time (rise)	ton	θ = 0° φ = 0°	-	50	80	ms
Response time (fall)	toff		-	100	160	
Response time (rise)	ton	θ = 0°, φ = 0° Ta=0°C Vopr=4.9V	-	200	320	ms
Response time (fall)	toff		-	450	720	
Response time (rise)	ton	θ = 0°, φ = 0° Ta=-20°C Vopr=5.0V	-	1500	2400	ms
Response time (fall)	toff		-	1500	2400	

■ Reference Drawing

Item	L167200P000	L1672B1P000
Dimensions	A	D
Block Diagram	B	E
Power supply	C	F
LED Backlight Circuit	--	G

L. Recommended Operating Voltage

The Recommended Value of (Vopr) for an ambient temperature is as follows.

$$Vopr = VDD - VLC$$

Temperature (°C)	-20	0	25	70
Vopr (V)	5.0	4.9	4.8	4.2

■ LED Backlight

L1672B1J000
-------------

M-1 Absolute Maximum Ratings

Ta = 25°C

Item	Symbol	Standard	Unit
LED Forward current consumption*	IF	200	mA
LED Reverse DC voltage	VR	8	V
LED Allowable dissipation	PD	0.92	W

\* Ambient temperature VS allowable forward current

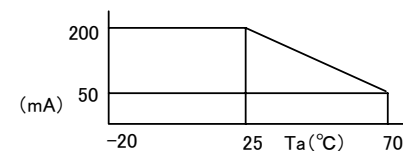

M-2 Optical Characteristics

Ta = 25°C

Item	Symbol	Conditions	Standard	Unit
Surface brightness (panel upper)	Bp	IF=112mA Vopr=0V	4 min. 5 typ.	cd/m <sup>2</sup>
LED reverse life			50,000 typ.	h
LED color			Yellow green	

LED forward current consumption and operating characteristics are as follows.

M-3 Electrical Characteristics

Ta = 25°C

Item/Condition	Symbol	Min.	Typ.	Max.	Unit
LED forward input Voltage IF=112mA	VF	3.8	4.1	4.4	V
LED reverse current VR=8V	IR	-	-	0.16	mA

## L1672

### Normal Temp STN LCD Module (White LED Backlight)

Type
L1672D1J000

#### ■ Electrical Characteristics

##### I. Absolute Maximum Ratings

VSS = 0V

Item	Symbol	Conditions	Min.	Max.	Unit
Power supply voltage	VDD		-0.3	6.0	V
	VLC		VDD-10	VDD+0.3	V
Input voltage	VIN		-0.3	VDD+0.3	V
Operating temperature	Topr		0	+50	°C
Storage temperature	Tstg		-20	+60	°C
Storage humidity		≤48hrs	+20	+85	%RH
		≤1000hrs	+20	+65	%RH

##### J. Electrical Characteristics

VDD = 5V ± 5%, VSS = 0V, Ta = 0°C ~ 50°C

Item	Symbol	Conditions	Min.	Typ.	Max.	Unit
Power supply voltage	VDD		4.75	5.0	5.25	V
	VDD-VLC			4.75		V
Input voltage*	High	VIH1	0.7Vdd	-	VDD	V
	Low	VIL1	-0.3	-	0.6	V
Output voltage**	High	VOH1	-IOH=0.1mA	3.9	-	VDD
	Low	VOL1	IOL=0.1mA	-	-	0.4
Current consumption	IDD	Ta=25°C VDD=5V	-	2.0	3.0	mA
	ILC	Vopr=4.75V	-	0.2	1.0	mA

\* Applied to DB0 ~ DB7, E, R/W, RS

Vopr = VDD - VLC

\*\* Applied to DB0 ~ DB7

##### K. Optical Characteristics

Viewing angle : 6 o'clock ( $\phi = 0^\circ$ ), Ta = 25°C, Vopr = 4.75V, Backlight OFF

Item	Symbol	Conditions	Min.	Typ.	Max.	Unit
Viewing angle	$\theta_1$	$C \geq 2.0$ $\phi = 0^\circ$	-	-	-10	deg.
	$\theta_2$		50	-	-	
	$\theta_2 - \theta_1$		60	-	-	
Contrast	C	$\theta = 20^\circ, \phi = 0^\circ$	2	4	-	-
Response time (rise)	t <sub>on</sub>	$\theta = 0^\circ$ $\phi = 0^\circ$	-	270	400	ms
Response time (fall)	t <sub>off</sub>		-	60	100	
Response time (rise)	t <sub>on</sub>	$\theta = 0^\circ, \phi = 0^\circ$ Ta=0°C Vopr=5.0V	-	720	1100	ms
Response time (fall)	t <sub>off</sub>		-	170	350	

#### ■ Reference Drawing

Item	L1672D1J000
Dimensions	D
Block Diagram	E
Power supply	F
LED Backlight Circuit	H

##### L. Recommended Operating Voltage

The Recommended Value of (Vopr) for an ambient temperature is as follows.

Vopr = VDD - VLC

Temperature(°C)	-	0	25	50
Vopr(V)	-	5	4.75	4.5

#### ■ LED Backlight

L1672D1J000

##### M-1 Absolute Maximum Ratings

Ta = 25°C

Item	Symbol	Standard	Unit
LED Forward current consumption*	IF	40	mA
Pulse current consumption t=1mSec, 1/10 Duty	IFD	96	mA
LED Reverse DC voltage	VR	5	V
LED Allowable dissipation	PD	120	mW

\* Ambient temperature VS allowable forward current

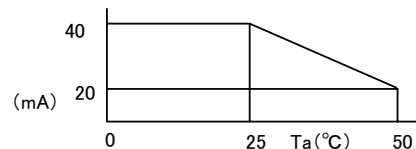

##### M-2 Optical Characteristics

Ta = 25°C

Item	Symbol	Conditions	Standard	Unit
Surface brightness (panel upper)	Bp	IF=30mA Vopr=0V	48 min. 80 typ.	cd/m <sup>2</sup>
Color (panel upper side)	x,y	IF=30mA Vopr=0V	0.26min 0.3typ 0.38max	---
LED reverse life			50,000 typ.	h
LED color			White	---

LED forward current consumption and operating characteristics are as follows.

##### M-3 Electrical Characteristics

Ta = 25°C

Item/Condition	Symbol	Min.	Typ.	Max.	Unit
input Voltage If=30mA	VF	3.2	3.6	4.0	V