

L1682

Features of L1682 Series

■ Basic Specifications

- 16 Characters × 2 lines
- STN gray type LCD is used
- 5 × 7 dot matrix + cursor
- 1/16 duty
- 5V single power supply

■ Line up

Type	LCD panel		LED backlight			Operating Temp
	Reflective	Transflective	yellow green	White	None	
L168200J000	●				●	Normal
L1682B1J000		●	●			
L168200P000	●				●	Wide temperature
L1682B1P000		●	●			
L1682D1J000		●		●		Normal

Pin Function

No.	No.	Name	Function
1	17	Vss	GND
2	18	VDD	Power supply voltage +5V
3	19	VLC	Liquid crystal driving voltage
4	20	RS	L: Instruction code input H: Data input
5	21	R/W	L: Data write (LCM→MPU) H: Data read (LCM→MPU)
6	22	E	Enable
7	23	DB0	Data bus line
8	24	DB1	Data bus line
9	25	DB2	Data bus line
10	26	DB3	Data bus line
11	27	DB4	Data bus line
12	28	DB5	Data bus line
13	29	DB6	Data bus line
14	30	DB7	Data bus line
15	31	VLED	Anode (1)
16	32	VLEDG	Cathode (1)

Remark1) LCD panel : NC as LCD Reflective type

L1682

■ Dimensions (D)

Type
L1682B1J000
L1682B1P000
L1682D1J000

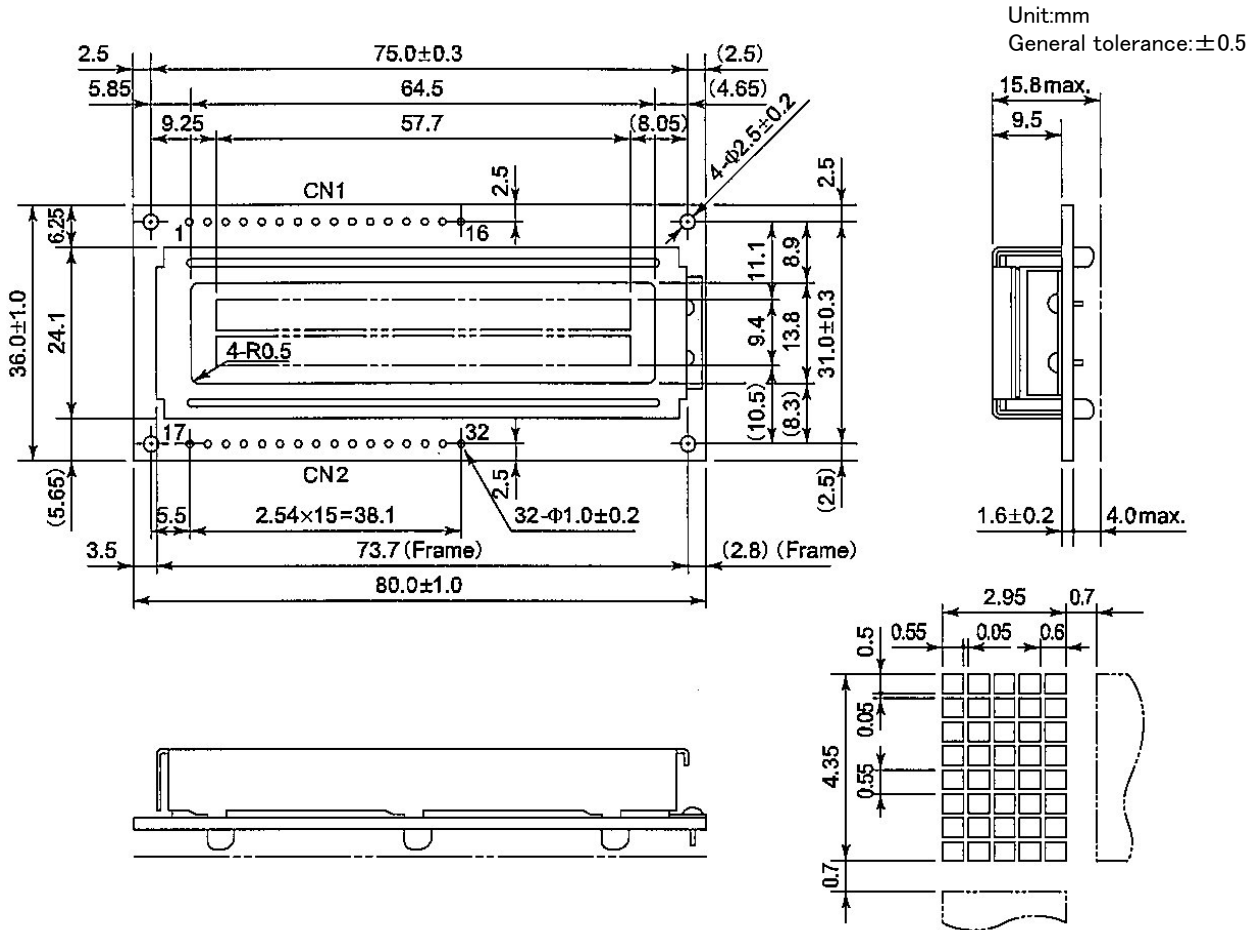

■ Block Diagram (E)

Type
L1682B1J000
L1682B1P000
L1682D1J000

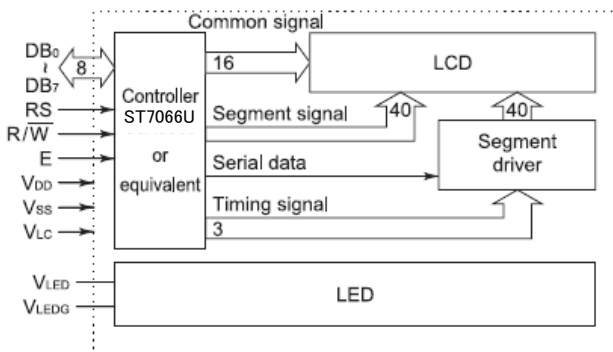

■ Power supply (F)

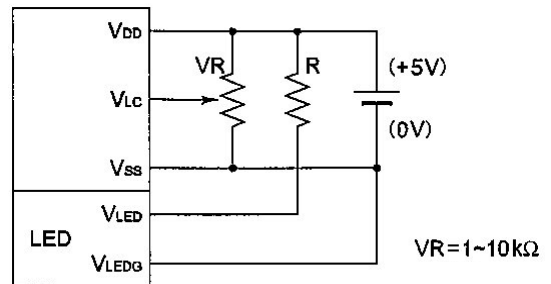

L1682

■ LED Backlight Circuit (G)

Type
L1682B1J000
L1682B1P000

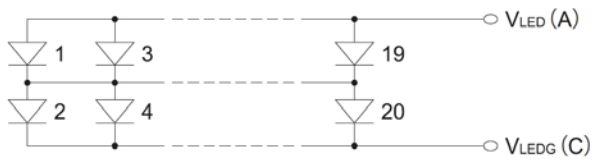

■ LED Backlight Circuit (H)

Type
L1682D1J000

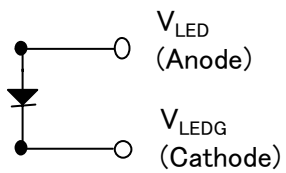

Normal Temp. STN LCD Module

Type
L168200J000
L1682B1J000

■ Electrical Characteristics

I. Absolute Maximum Ratings

VSS = 0V

Item	Symbol	Conditions	Min.	Max.	Unit
Power supply voltage	VDD		-0.3	6.0	V
	VLC		VDD-10	VDD+0.3	V
Input voltage	VIN		-0.3	VDD+0.3	V
Operating temperature	Topr		0	+50	°C
Storage temperature	Tstg		-20	+60	°C
Storage humidity		≤48hrs	+20	+85	%RH
		≤1000hrs	+20	+65	%RH

J. Electrical Characteristics

VDD = 5V ± 5%, VSS = 0V, Ta = 0°C ~ 50°C

Item	Symbol	Conditions	Min.	Typ.	Max.	Unit
Power supply voltage	VDD		4.75	5.0	5.25	V
	VDD-VLC			4.75		V
Input voltage*	High	VIH1	0.7Vdd	-	VDD	V
	Low	VIL1	-0.3	-	0.6	V
Output voltage**	High	VOH1	-IOH=0.1mA	3.9	VDD	V
	Low	VOL1	IOL=0.1mA	-	0.4	V
Current consumption	IDD	Ta=25°C VDD=5V	-	1.5	3.0	mA
	ILC	Vopr=4.75V	-	0.3	1.0	mA

* Applied to DB0 ~ DB7, E, R/W, RS

Vopr = VDD - VLC

** Applied to DB0 ~ DB7

K. Optical Characteristics

L168200J000

Viewing angle : ($\phi = 0^\circ$), Ta = 25°C, Vopr = 4.75V

Item	Symbol	Condition	Min.	Typ.	Max.	Unit
Viewing angle	θ_1	$C \geq 2.0$ $\phi = 0^\circ$	-	-	-15	deg.
	θ_2		55	-	-	
	$\theta_2 - \theta_1$		70	-	-	

L1682B1J000

Viewing angle : 6 o'clock ($\phi = 0^\circ$), Ta = 25°C, Vopr = 4.75V, Backlight OFF

Item	Symbol	Condition	Min.	Typ.	Max.	Unit
Viewing angle	θ_1	$C \geq 2.0$ $\phi = 0^\circ$	-	-	-10	deg.
	θ_2		50	-	-	
	$\theta_2 - \theta_1$		60	-	-	

Common Optical Characteristics

Viewing angle : 6 o'clock ($\phi = 0^\circ$), Ta = 25°C, Vopr = 4.75V, (Backlight OFF)

Item	Symbol	Condition	Min.	Typ.	Max.	Unit
Contrast	C	$\theta = 20^\circ, \phi = 0^\circ$	2	4	-	-
Response time (rise)	ton	$\theta = 0^\circ$ $\phi = 0^\circ$	-	270	400	ms
Response time (fall)	toff		-	60	100	
Response time (rise)	ton	$\theta = 0^\circ, \phi = 0^\circ$ Ta=0°C Vopr=5.0V	-	720	1100	ms
Response time (fall)	toff		-	170	350	

■ Reference Drawing

Item	L168200J000	L1682B1J000
Dimensions	A	D
Block Diagram	B	E
Power supply	C	F
LED Backlight Circuit	--	G

L. Recommended Operating Voltage

The Recommended Value of (Vopr) for an ambient temperature is as follows.

Vopr = VDD - VLC

Temperature (°C)	-	0	25	50
Vopr (V)	-	5	4.75	4.5

■ LED Backlight

L1682B1J000

M-1 Absolute Maximum Ratings

Ta = 25°C

Item	Symbol	Standard	Unit
LED Forward current consumption*	IF	200	mA
LED Reverse DC voltage	VR	8	V
LED Allowable dissipation	PD	0.8	W

* Ambient temperature VS allowable forward current

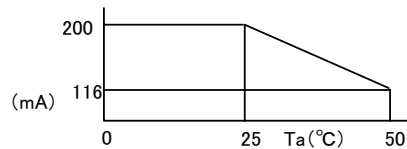

M-2 Optical Characteristics

Ta = 25°C

Item	Symbol	Conditions	Standard	Unit
Surface brightness (panel upper)	Bp	IF=100mA A Vopr=0V	4 min. 5 typ.	cd/m ²
LED reverse life			50,000 typ.	h
LED color			Yellow green	

LED forward current consumption and operating characteristics are as follows.

M-3 Electrical Characteristics

Ta = 25°C

Item/Condition	Symbol	Min.	Typ.	Max.	Unit
LED forward input Voltage If=240mA	VF	3.8	4.1	4.4	V
LED reverse current VR=8V	IR	-	-	2.4	mA

Wide Temp. STN LCD Module

Type
L168200P000
L1682B1P000

■ Electrical Characteristics

I. Absolute Maximum Ratings

VSS = 0V					
Item	Symbol	Conditions	Min.	Max.	Unit
Power supply voltage	VDD		-0.3	6.0	V
	VLC		VDD-10	VDD+0.3	V
Input voltage	VIN		-0.3	VDD+0.3	V
Operating temperature	Topr		-20	+70	°C
Storage temperature	Tstg		-30	+80	°C
Storage humidity		≤48hrs	+20	+85	%RH
		≤1000hrs	+20	+65	%RH

J. Electrical Characteristics

VDD = 5V ± 5%, VSS = 0V, Ta = -20°C ~ 70°C						
Item	Symbol	Conditions	Min.	Typ.	Max.	Unit
Power supply voltage	VDD		4.75	5.0	5.25	V
	VDD-VLC			4.8		V
Input voltage*	High	VIH1	0.7Vdd	-	VDD	V
	Low	VIL1	-0.3	-	0.6	V
Output voltage**	High	VOH1	-IOH=0.1mA	3.9	-	VDD
	Low	VOL1	IOL=0.1mA	-	-	0.4
Current consumption	IDD	Ta=25°C VDD=5V	-	1.5	3.0	mA
	ILC	Vopr=4.75V	-	0.3	1.0	mA

* Applied to DB0 ~ DB7, E, R/W, RS

** Applied to DB0 ~ DB7

K. Optical Characteristics

L168200P000						
Viewing angle : 6 o'clock (φ = 0°), Ta = 25°C, Vopr = 4.8V						
Item	Symbol	Condition	Min.	Typ.	Max.	Unit
Viewing angle	θ ₁	C ≥ 2.0 φ = 0°	-	-	0	deg.
	θ ₂		50	-	-	
	θ ₂ - θ ₁		50	-	-	

L1682B1P000						
Viewing angle : 6 o'clock (φ = 0°), Ta = 25°C, Vopr = 4.8V, Backlight OFF						
Item	Symbol	Condition	Min.	Typ.	Max.	Unit
Viewing angle	θ ₁	C ≥ 2.0 φ = 0°	-	-	0	deg.
	θ ₂		50	-	-	
	θ ₂ - θ ₁		50	-	-	

Common Optical Characteristics

Viewing angle : 6 o'clock (φ = 0°), Ta = 25°C, Vopr = 4.8V, Backlight OFF						
Item	Symbol	Condition	Min.	Typ.	Max.	Unit
Contrast	C	θ = 20°, φ = 0°	2	3	-	-
Response time (rise)	ton	θ = 0° φ = 0°	-	50	80	ms
Response time (fall)	toff		-	100	160	
Response time (rise)	ton	θ = 0°, φ = 0° Ta=0°C Vopr=4.9V	-	200	320	ms
Response time (fall)	toff		-	450	720	
Response time (rise)	ton	θ = 0°, φ = 0° Ta=-20°C Vopr=5.0V	-	1500	2400	ms
Response time (fall)	toff		-	1500	2400	

■ Reference Drawing

Item	L168200P000	L1682B1P000
Dimensions	A	D
Block Diagram	B	E
Power supply	C	F
LED Backlight Circuit	--	G

L. Recommended Operating Voltage

The Recommended Value of (Vopr) for an ambient temperature is as follows.

Temperature (°C)	Vopr = VDD - VLC			
	-20	0	25	70
Vopr (V)	5.0	4.9	4.8	4.2

■ LED Backlight

L1682B1J000			
M-1 Absolute Maximum Ratings			
Ta = 25°C			
Item	Symbol	Standard	Unit
LED Forward current consumption*	IF	200	mA
LED Reverse DC voltage	VR	8	V
LED Allowable dissipation	PD	0.8	W

* Ambient temperature VS allowable forward current

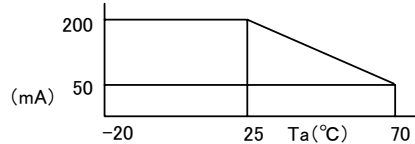

M-2 Optical Characteristics

Ta = 25°C				
Item	Symbol	Conditions	Standard	Unit
Surface brightness (panel upper)	Bp	IF=100mA Vopr=0V	4 min. 5 typ.	cd/m ²
LED reverse life			50,000 typ.	h
LED color			Yellow green	

LED forward current consumption and operating characteristics are as follows.

M-3 Electrical Characteristics

Ta = 25°C					
Item/Condition	Symbol	Min.	Typ.	Max.	Unit
LED forward input Voltage If=200mA	VF	3.8	4.1	4.4	V
LED reverse current VR=8V	IR	-	-	2.4	mA

Normal Temp STN LCD Module (White LED Backlight)

Type
L1682D1J000

■ Electrical Characteristics

I. Absolute Maximum Ratings

VSS = 0V

Item	Symbol	Conditions	Min.	Max.	Unit
Power supply voltage	VDD		-0.3	6.0	V
	VLC		VDD-10	VDD+0.3	V
Input voltage	VIN		-0.3	VDD+0.3	V
Operating temperature	Topr		0	+50	°C
Storage temperature	Tstg		-20	+60	°C
Storage humidity		≤48hrs	+20	+85	%RH
		≤1000hrs	+20	+65	%RH

J. Electrical Characteristics

VDD = 5V ± 5%, VSS = 0V, Ta = 0°C ~ 50°C

Item	Symbol	Conditions	Min.	Max.	Unit		
Power supply voltage	VDD		4.75	5.0	5.25	V	
	VDD-VLC			4.75		V	
Input voltage*	High	VIH1	0.7Vdd	-	VDD	V	
	Low	VIL1	-0.3	-	0.6	V	
Output voltage**	High	VOH1	-IOH=0.1mA	3.9	-	VDD	V
	Low	VOL1	IOL=0.1mA	-	-	0.4	V
Current consumption	IDD	Ta=25°C VDD=5V	-	1.5	3.0	mA	
	ILC	Vopr=4.75V	-	0.3	1.0	mA	

* Applied to DB0 ~ DB7, E, R/W, RS

Vopr = VDD - VLC

** Applied to DB0 ~ DB7

K. Optical Characteristics

Viewing angle : 6 o'clock (φ = 0°), Ta = 25°C, Vopr = 4.75V, Backlight OFF

Item	Symbol	Conditions	Min.	Typ.	Max.	Unit
Viewing angle	θ ₁	C ≥ 2.0 φ = 0°	-	-	-10	deg.
	θ ₂		50	-	-	
	θ ₂ - θ ₁		60	-	-	
Contrast	C	θ = 20°, φ = 0°	2	4	-	-
Response time (rise)	ton	θ = 0°, φ = 0°	-	270	400	ms
Response time (fall)	toff		-	60	100	
Response time (rise)	ton	θ = 0°, φ = 0° Ta=0°C Vopr=5.0V	-	720	1100	ms
Response time (fall)	toff		-	170	350	

■ LED Backlight

Item	L1682D1J000
Dimensions	D
Block Diagram	E
Power supply	F
LED Backlight Circuit	H

L. Recommended Operating Voltage

The Recommended Value of (Vopr) for an ambient temperature is as follows.

Vopr = VDD - VLC

Temperature (°C)	-	0	25	50
Vopr (V)	-	5	4.75	4.5

■ LED Backlight

L1682D1J000

M-1 Absolute Maximum Ratings

Ta = 25°C

Item	Symbol	Standard	Unit
LED Forward current consumption*	IF	20	mA
Pulse current consumption t=1mSec, 1/10 Duty	IFD	48	mA
LED Reverse DC voltage	VR	5	V
LED Allowable dissipation	PD	60	mW

* Ambient temperature VS allowable forward current

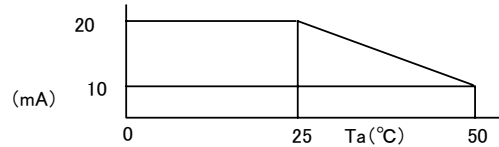

M-2 Optical Characteristics

Ta = 25°C

Item	Symbol	Conditions	Standard	Unit
Surface brightness (panel upper)	Bp	IF=15mA Vopr=0V	10 min. 20 typ.	cd/m ²
Color (panel upper side)	x,y	IF=15mA Vopr=0V	0.26min 0.3typ 0.38max	---
LED reverse life			50,000 typ.	h
LED color			White	---

LED forward current consumption and operating characteristics are as follows.

M-3 Electrical Characteristics

Ta = 25°C

Item/Condition	Symbol	Min.	Typ.	Max.	Unit
LED forward input Voltage If=15mA	VF	3.2	3.6	4.0	V