

Liquid Crystal Display Module
With A Touch Panel
Technical Data

General Research of Electronics, Inc.

Introduction

This manual describes the specifications and data for the liquid crystal display module with a touch panel. This manual is not allowed to be distributed to any third party for the purpose of other than the use by our customers. The information and data contained herein are subject to change without prior notice.

With respect to applications to other products, drive circuits and so on, not specified in this manual, GRE shall not be responsible for any industrial property possessed by any third party.

Revision Record

<u>Edition</u>	<u>Revision</u>	<u>Date</u>
1	Original	June 2006

Table of Contents

1. General Description	1
2. Touch Panel	
2.1 Structure	1
2.2 Characteristics	1
2.3 Chemical Resistance of Touch Panel Surface	3
2.4 Handling Precautions	5
3. Liquid Crystal Display Module With A Touch Panel:G321EV5B00X/G321EV5R00X	
3.1 General Description	6
3.2 Mechanical Characteristics	6
3.3 Optical Characterstics	6
3.4 Maximum Absolute Rating, Electrical Characteristics	
Recommended Operating Voltage (Vopr)	7
3.5 Outline Dimensions	8
3.6 Input and Output Terminals	9
3.7 Interface Circuit Example	11

1. General Description

In the liquid crystal display (LCD) module with a touch panel, a transparent touch switch is mounted on the LCD display screen. The switching functions are displayed on the LCD display screen, from which you can select a desirable switch using your fingertip. Therefore, changing the display contents allows you to change the functions of the switch. This switch is a small size and multifunctional switch.

The applications cover office and factory automation equipment and instruments.

2. Touch Panel

2.1. Structure

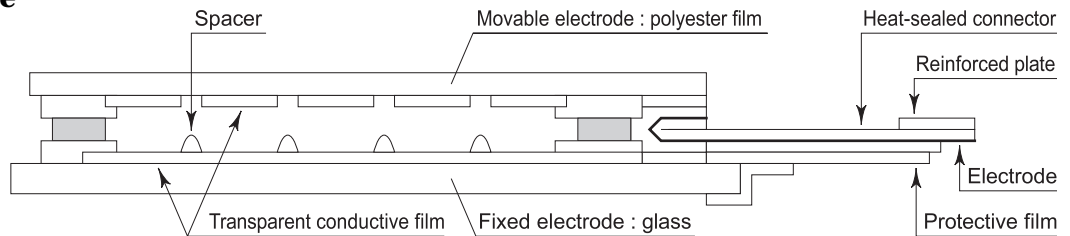

2-2. Characteristics

(1) Temperature Range

Item	Symbol	Conditions	Standard	Unit
Operating temp. range	T_{opr}	Less than 85%RH, non condensing	0 to +50	°C
Storage temp. range	T_{stg}	Less than 90%RH, non condensing	-20 to +60	°C

(2) Ratings

Item	Symbol	Conditions	Standard			Unit
			min.	typ.	max.	
Input Voltage	V_{IN}		—	—	5	V DC
Input Current	I_{IN}		—	—	1	mA

(3) Mechanical Characteristics

Item	Symbol	Test Method	Standard			Unit
			min.	typ.	max.	
Operation force	F	After being pressed using a silicon rubber bar of end radius 3 mm, diameter $\phi 6\text{mm}$, rubber hardness 60°, test the force obtained when the contact resistance stabilizes.	—	—	100	gf
Heat seal strength		Peel-off test at 90°	150	—	—	g/cm
Surface hardness		Pencil hardness test : JIS K5400	2H	—	—	—
Input method		—	Input only using fingertip. DO NOT INPUT USING FINGERNAIL.			—

(4) Electrical Characteristics

Item	Symbol	Conditions	Standard			Unit
			min.	typ.	max.	
Bounce Chattering ¹	t _{ON}			—	20	ms
	t _{OFF}			—	20	ms
Contact Resistance ²	R _p			—	9	kΩ
Insulation Resistance ³	R _r		10	—	—	MΩ

1 Configure the circuit as shown below. Press the center of the arbitrary key on the touch panel at 300 gf using a silicone rubber bar to activate the switch. Measure the bounce chattering when this switch is ON and OFF. The silicone rubber bar shall be end radius 3 mm, diameter φ6 mm, and rubber hardness 60°.

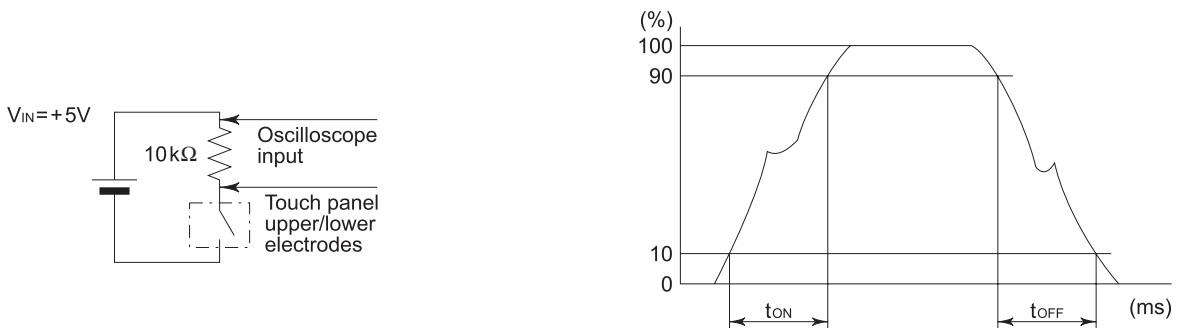

2 Press the center of the arbitrary key on the touch panel at 300 gf using silicone rubber bar to activate the switch. Measure the contact resistance between upper and lower terminals of the switch. The silicone rubber bar shall be end radius 3mm, diameter φ6 mm, and rubber hardness 60°.

3 Apply input voltage (V_{IN}) 50 V between the switch terminals. Measure the insulation resistance between adjacent terminals and between upper and lower terminals of the switch.

(5) Key Operation Life

Item	Conditions	Criteria	Standard	Unit
Key Operation Life	V _{IN} = 5V DC I _{IN} = 1 mA Pressure : 300±100 gf Test bar : A silicone rubber bar of end radius 3 mm, diameter φ6 mm, and rubber hardness 60°	Conform to electrical characteristics standard (bounce chattering, contact resistance, insulation resistance).	More than 1,000,000	times

2.3 Chemical Resistance of Touch Panel Surface

2.3.1 General Chemicals

(1) Polyester Film on the Surface

Chemicals		Conditions and Result	
		Room tem. for 7days	At 70°C, for 7days
Acid	Acetic acid	○	△
	10% Hydrochloric acid	○	△
	Conc. hydrochloric acid	△	×
	10% Nitric acid	○	△
	Concentrated nitric acid	×	×
	10% Sulfuric acid	○	△
	Concentrated sulfuric acid	×	×
Alkaline	10% Ammonia solution	△	×
	Conc. ammonia solution	×	×
	10% Caustic soda	×	×
Solvent	Benzene	○	○
	Toluene	○	○
	Acetone	○	○
	Ethanol	○	○
	Solvent naphtha	○	○
	Chloroform	○	△
	Methyl-ethyl-ketone	○	△
	Acetic acid ethyl	○	△

○ : resistant, △ : reduction in strength (approx. 10%), × : no resistance

(2) Surface Coating Material (hard coating, non-glare coating)

Chemicals		Conditions	Result
Acid Alkaline	35% Hydrochloric acid	Moisten for 30 min.	○
	28% Ammonia solution	Moisten for 12 hours	○
	5% Caustic soda	Moisten for 5 hours	○
Solvent	Toluene	Moisten for 12 hours	○
	Acetone	Moisten for 12 hours	○
	Methyl-ethyl-ketone	Moisten for 12 hours	○
	Chloroform	Moisten for 12 hours	○
	Acetic acid ethyl	Moisten for 12 hours	○
	Acetic acid butyl	Moisten for 12 hours	○
	Ethanol	Moisten for 12 hours	○

○ : resistant, △ : reduction in strength (approx. 10%), × : no resistance

2.3.2 Household Materials

(1) Polyester Film on the Surface

Materials	Conditions	Results
Vinegar	for 24 hours	No abnormality in external appearance
Salad oil	for 24 hours	No abnormality in external appearance
Soy sauce	for 24 hours	No abnormality in external appearance
Worcester sauce	for 24 hours	No abnormality in external appearance
Butter	for 24 hours	No abnormality in external appearance
Coffee	for 24 hours	No abnormality in external appearance

(2) Surface Coating Material (hard coating, non-glare coating)

Materials	Conditions	Results	
		Thickness	External Appearance
Hand cream	For 6 months	No change	No abnormality
Sweat (artificial)	For 6 months	No change	No abnormality
Fingerprint (artificial)	For 6 months	No change	No abnormality
Water	For 6 months	No change	No abnormality
Machine oil	For 6 months	No change	No abnormality

2.4 Handling Precautions

(1) Storage

- Do not leave this product in water and organic solution or in an atmosphere of acid.

(2) Handling

- Do not place any heavy weights on the touch panel.
- Do not apply excessive shock to this product and do not drop it.
- To remove stains from the surface of the product, wipe gently with a soft dry cloth or a soft cloth that has been dampened with a small amount of ethanol.
- Do not handle the heat seal connector (when handling the product).

(3) Assembly

- Assemble so that the housing does not apply excessive stress to the touch panel.
- The heat seal part is easily disconnected. So, be sure not so as to apply excessive stress to the heat seal part.
- In order to equalize the external and internal pressures, the touch panel is provided with an air groove. If water or oil exists in the vicinity of the groove, such a solution may penetrate into the inside. Be sure that such a solution does not remain in the vicinity of the groove.

(4) Operation

- Only fingertip input is allowable. Do not input using any hard object or sharp-edged tool.

3. Liquid Crystal Display Module With a Touch Panel: G321EV5B00X/G321EV5R00X

3.1 General Description

- Transparent touch panel
 - 10 × 6 key matrix
 - Non-glare
- Blue mode:G321EV5B00X
- Black & White mode: G321EV5R00X
- CFL backlight

3.2 Mechanical Characteristics

Item	Standard	Unit
Dot format (H × V)	320 × 240	Dot
Dot size (H × V), typ.	0.27 × 0.27	mm
Dot pitch (H × V), typ.	0.30 × 0.30	mm
Module size (H typ. × V typ. × D max.)	150.0 × 97.0 × 16.0	mm
Viewing area (H × V), typ.	103.0 × 79.4	mm
Active display area (H × V), typ.	95.97 × 71.97	mm
Weight, typ.	240	g

3.3 Optical Characteristics

(1) G321EV5B00X

1/240 duty, 1/13.1 bias, $V_{opr}=V_{DD}-V_o$

Item	Symbol	Conditions	Temp.	min.	typ.	max.	Unit
Contrast	C	$\theta=0^\circ$ $\phi=0^\circ$ $V_{opr}=21.2V$	25°C	2.0	3.0	—	—
Viewing angle	θ_1	$C \geq 2.0^\circ$ $\phi=0^\circ$ $V_{opr}=21.2V$	25°C	—	—	-15	degree
	θ_2			20	—	—	
	$\theta_2-\theta_1$			35	—	—	
Response time	t_{on}	$\theta=0^\circ$ $\phi=0^\circ$ $V_{opr}=21.2V$	25°C	—	170	260	ms
	t_{off}			—	190	290	
	t_{on}	$\theta=0^\circ$ $\phi=0^\circ$ $V_{opr}=22.8V$	0°C	—	1100	1700	
	t_{off}			—	500	750	

(2) G321EV5R00X

1/240 duty, 1/13.1 bias, $V_{opr}=V_{DD}-V_O$

Item	Symbol	Conditions	Temp.	min.	typ.	max.	Unit
Contrast	C	$\theta=-10^\circ$ $\phi=0^\circ$ $V_{opr}=20.6V$	25°C	3.0	6.0	—	—
Viewing angle	θ_1	$C \geq 2.0$ $\phi=0^\circ$ $V_{opr}=20.6V$	25°C	—	—	-15	degree
	θ_2			30	—	—	
	$\theta_2-\theta_1$			45	—	—	
Response time	t_{on}	$\theta=0^\circ$ $\phi=0^\circ$ $V_{opr}=20.6V$	25°C	—	230	350	ms
	t_{off}			—	150	230	
	t_{on}	$\theta=0^\circ$ $\phi=0^\circ$ $V_{opr}=22.4V$	0°C	—	1100	1700	
	t_{off}			—	500	750	

3.4 Maximum Absolute Rating, Electrical Characteristics, Recommended Operating Voltage (V_{opr})

(1) G321EV5B00X

The maximum absolute rating, electrical characteristics and recommended operating voltage (V_{opr}) are the same as those for the standard module G321EV5B000.

(2) G321EV5R00X

The maximum absolute rating, electrical characteristics and recommended operating voltage (V_{opr}) are the same as those for the standard module G321EV5R000.

3.6 Input and Output Terminals

(1) LCD

CN1

No.	Symbol	Function
1	FLM	1 frame timing signal
2	M	NC (or liquid crystal AC drive control signal)
3	CL1	1 common line timing signal
4	CL2	Display data shift clock
5	$\overline{\text{DISPOFF}}$	Display ON/OFF control ¹
6	D ₀	Display data input
7	D ₁	Display data input
8	D ₂	Display data input
9	D ₃	Display data input
10	V _{DD}	Power supply voltage (1): +5V
11	V _{SS}	GND: 0V
12	V _{LC}	Power supply voltage (2): -24V
13	V _O	Liquid crystal drive voltage adjustment terminal
14	F _{GND}	Frame GND ²

¹ The display comes on at $\overline{\text{DISPOFF}}=\text{"H,"}$ and goes out at $\overline{\text{DISPOFF}}=\text{"L."}$

² F_{GND} is connected to the metallic frame of the module. So, use when grounding the frame.

(2) CFL Backlight

CN2

Connector for CFL: Socket IL-G-3S-S3C2(JAE),

Socket contact: IL-G-C2-SC-10000(JAE)

Applicable connectors (directly connected to substrate):

IL-G-3P-S3T2-E(straight type)(JAE)

IL-G-3P-S3L2-E(right-angle type)(JAE)

No.	Symbol	Color of wire	Function
1	V _{FL}	black	GND ¹ : 0 V
2	NC	—	unused
3	V _{FL1}	red	CFL backlight drive signal

¹ V_{FL} is not connected to V_{SS} (GND) of CN1.

(3) Touch Panel

No.	Symbol	Function
1	X6	SW6, SW16, SW26, SW36, SW46, SW56 output (input) line
2	X5	SW5, SW15, SW25, SW35, SW45, SW55 output (input) line
3	X4	SW4, SW14, SW24, SW34, SW44, SW54 output (input) line
4	X3	SW3, SW13, SW23, SW33, SW43, SW53 output (input) line
5	X2	SW2, SW12, SW22, SW32, SW42, SW52 output (input) line
6	Y6	SW1 to SW10 input (output) line
7	Y5	SW11 to SW20 input (output) line
8	Y4	SW21 to SW30 input (output) line
9	Y3	SW31 to SW40 input (output) line
10	Y2	SW41 to SW50 input (output) line
11	Y1	SW51 to SW60 input (output) line
12	X1	SW1, SW11, SW21, SW31, SW41, SW51 output (input) line
13	X7	SW7, SW17, SW27, SW37, SW47, SW57 output (input) line
14	X8	SW8, SW18, SW28, SW38, SW48, SW58 output (input) line
15	X9	SW9, SW19, SW29, SW39, SW49, SW59 output (input) line
16	X10	SW10, SW20, SW30, SW40, SW50, SW60 output (input) line

* Key Matrix

	X1	X2	X3	X4	X5	X6	X7	X8	X9	X10
Y6	SW1	SW2	SW3	SW4	SW5	SW6	SW7	SW8	SW9	SW10
Y5	SW11	SW12	SW13	SW14	SW15	SW16	SW17	SW18	SW19	SW20
Y4	SW21	SW22	SW23	SW24	SW25	SW26	SW27	SW28	SW29	SW30
Y3	SW31	SW32	SW33	SW34	SW35	SW36	SW37	SW38	SW39	SW40
Y2	SW41	SW42	SW43	SW44	SW45	SW46	SW47	SW48	SW49	SW50
Y1	SW51	SW52	SW53	SW54	SW55	SW56	SW57	SW58	SW59	SW60

** Mating Connector

- Straight type
 - IL-FPC-16S-S1T1(JAE)
 - IL-404-16S-TW(JAE)
- Right-angle type
 - IL-FPC-16S-S1L1(JAE)
 - IL-404-16S-LW(JAE)

3.7 Interface Circuit Example

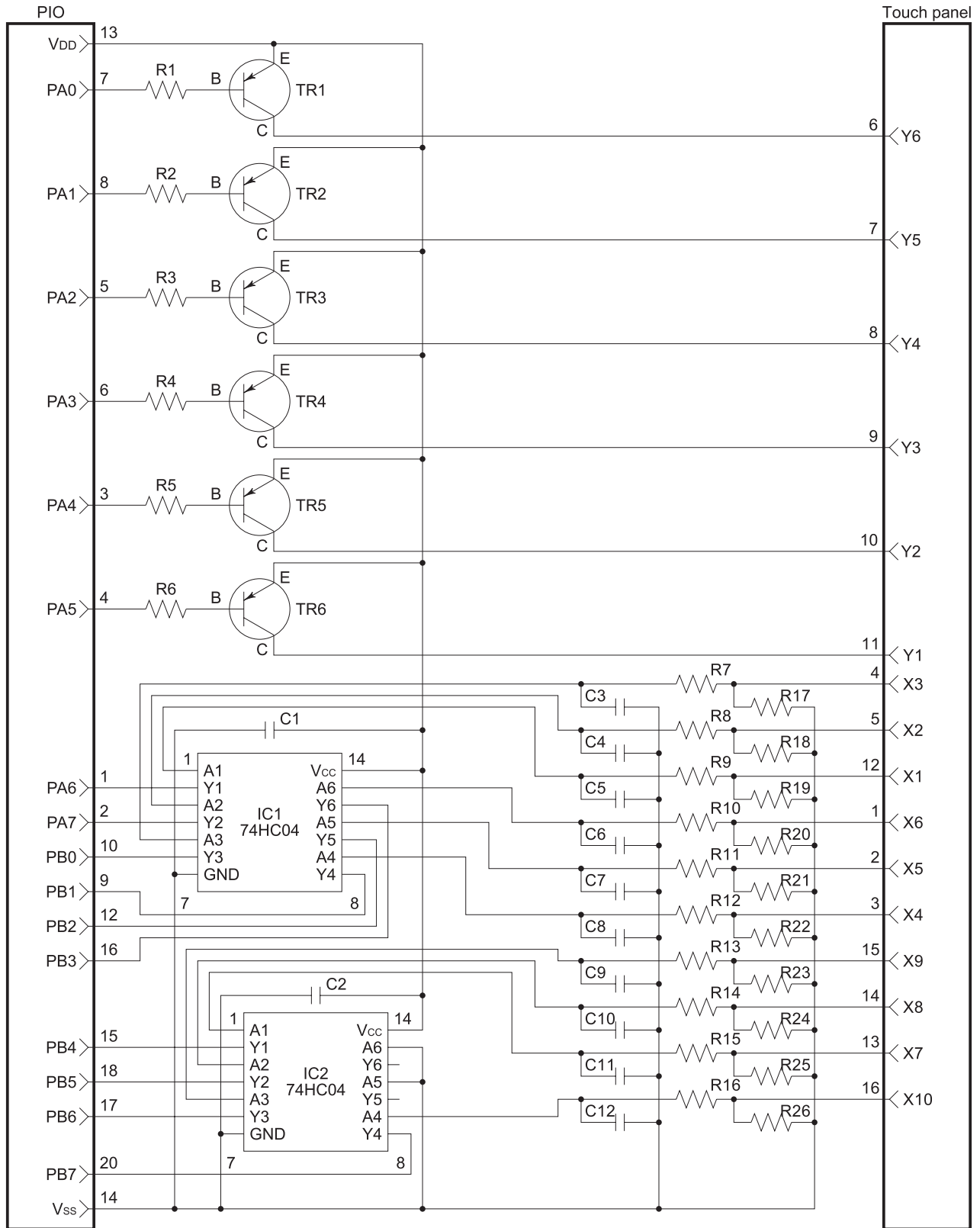

(Example) TR1 to TR6: 2SA1015
R1 to R6: 3.3kΩ:(1 to 10kΩ)
R17 to R26: 330kΩ:(100 to 500kΩ)
C1, C2: 0.1μF
R7 to R16: 10kΩ, C3 to C12: 0.1μF:($R(n + 4) \times C_n = 1\text{ms}$, $n=3$ to 12)

This circuit functions as follows;

Scan PA₀ to PA₅ in order to change the signal from “1” to “0” and output. These signals are converted through TR₁ to TR₆, and “1” is output to terminal Y of the touch panel. Terminal X is pulled down by R₁₇ to R₂₆ to become “0”.

Pressing the switch provided with the touch panel changes terminal X from “0” to “1” when the crossed terminal Y becomes “1” when scanning. Other X terminals remain “0”. That is, if terminal X_m becomes “1” at a time when terminal Y_n becomes “1” when scanning, this means that the switch intercrossing electrode X_m and electrode Y_n is pressed. The signal of terminal X is reversed in circuits IC₁ and IC₂, and is output to input terminals PA₆, PA₇ and PB₀ to PB₇ of PIO.

For easy operation, it is advisable to display the area, functions, and explanation of the switch using the LCD which is mounted under the touch panel.

Taking into consideration the bounce chattering standard, set the scanning speed to more than 20 msec.

General Research of Electronics, Inc.

Standard LCM Business Section

3-12-17 Mita, Minato-ku, Tokyo 108-0073, Japan

Telephone: 03-5439-3611 Facsimile: 03-5439-3644

web: <http://www.gre.co.jp> e-mail: lcm-sales@gre.co.jp